



AN UNCOMMON TECHNICAL RESOURCE
(413) 788-LUBE (5823)
www.LubeTechnologies.com

Yamada

Doc. No. OSA037U-03

INSTRUCTION

ELECTRIC GREASE LUBRICATOR

(AC-100V 50/60Hz)

EPL-100 MODEL No.880899

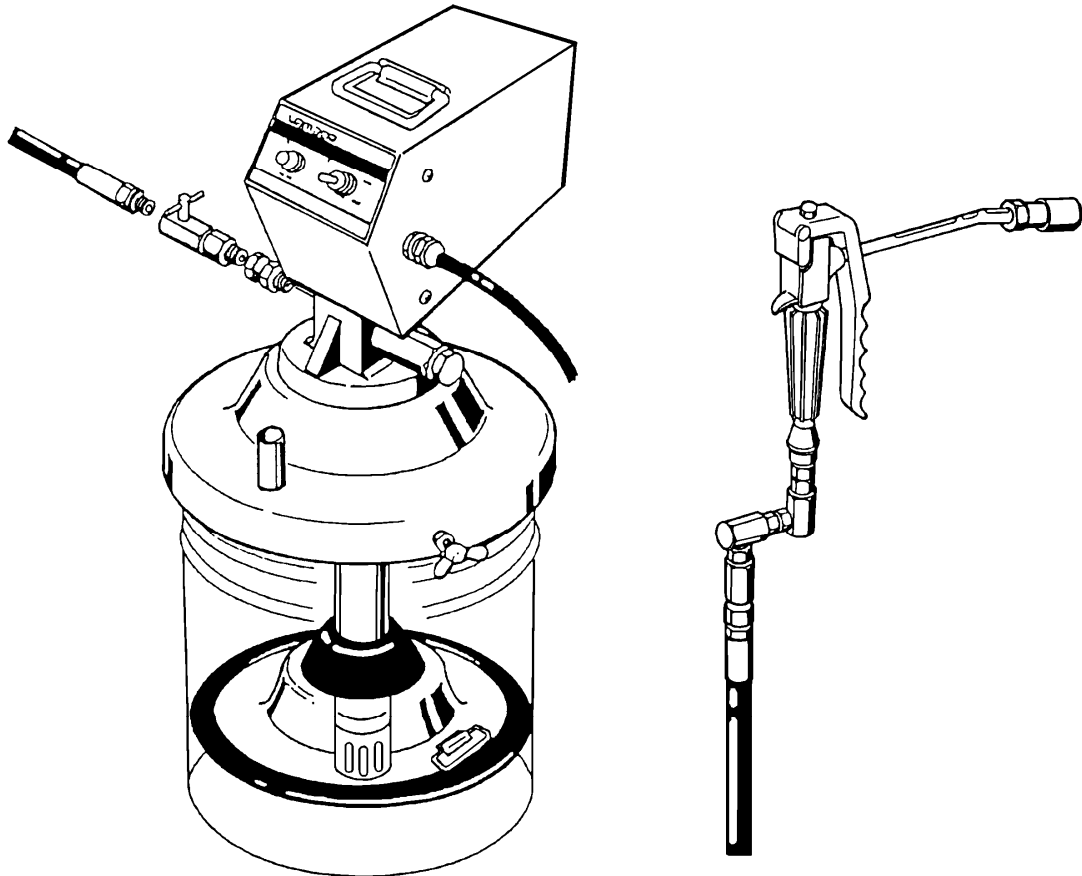

WARNING

Prior to operating this pump, be sure to read this operation manual for safety. After reading the manual, please keep it at hand any time for your quick reference.

The power supply cannot be used other than AC100V.

YAMADA CORPORATION



AN UNCOMMON TECHNICAL RESOURCE
(413) 788-LUBE (5823)
www.LubeTechnologies.com

- Preface

Thank you very much for purchasing Yamada Pump. This machine is a portable type lubricator that is indispensable for grease lubrication for machines and vehicles. The pump is driven by AC-100V (50/60Hz). This lubricator cannot be used for oil lubrication. The applicable grease is limited to a type of NLGI No.2 or less in the normal operating conditions. If the lubricator is used in an extremely cold or low-temperature environment, the discharge volume will be remarkably lowered. Silicone grease is not applicable.

- For Safe Operation

This document describes the items that are important for the user to operate this product safely, correctly, and efficiently. Before operating this product, read this manual thoroughly, in particular, "Warnings and Cautions" at the beginning of this manual, with a good understanding of its contents. Keep this manual carefully in an easy-to-access place so that the user may refer to it whenever necessary.

- Warnings and Cautions

To use this product safely, be sure to observe the contents of the following description. In this manual, warnings and cautions are indicated by using symbols. These symbols are intended to prevent death or serious injury that may be caused to the operator or those who are around the product and damage that may be caused to the articles that are around the product, as well as to use the product safely and correctly. Each symbol is indicated and has a meaning as shown below. Read the description with a good understanding of its contents.



WARNING : This indicates the existence of potential hazard which, if not avoided, will result in death or serious injury.



CAUTION : This indicates the existence of potential hazard which, if not avoided, may result in bodily injury or in physical damage.

To indicate the contents of danger and damage, the following symbols are used together with the above indications.



This symbol indicates an act that is prohibited (prohibition). The concrete contents of prohibition are indicated by the side of the indication.





This symbol indicates the contents that must be observed. The concrete contents of observance are indicated by the side of the indication.





AN UNCOMMON TECHNICAL RESOURCE
(413) 788-LUBE (5823)
www.LubeTechnologies.com

- Precautions on Use

The following warnings and cautions are very important. Be sure to observe them.

 WARNING	
	<ul style="list-style-type: none">- Gasoline is a high-volatility material. Do not use gasoline to clean the pump in any case, otherwise it may cause ignition or explosion.- Remodeling this machine may result in a bodily accident or failure. Do not remodel the machine in any case, otherwise it will invite danger.- The material to be discharged from this machine may become a hazardous object depending on its nature. Be sure to discharge it in a vessel. Do not discharge it directly on the ground.- This machine uses aluminum alloy for the liquid contact section of machine and NBR for the seal section, respectively. Any solvent or chemical which corrode these materials is not available. If used, corrosion could lead to a liquid leak, resulting in damages on the human body or properties.
	<ul style="list-style-type: none">- If the material handled come into direct contact with or is splashed over your body, it could be harmful to the eye or skin. Be sure to check the material handled, and when you work with it, put on a protective gear (protective mask, glasses, safety gloves, etc.) depending on the degree of danger.- Some types of grease may contain a carcinogenic material. Read the cautions for handling grease given by the grease maker carefully when handling the grease.

 CAUTION	
	<ul style="list-style-type: none">- Do not operate the gun lever with the discharge port facing to another person during machine operation in any case. A direct hit against the human body may result in an accident such as skin damage.- The operator or administrator of this pump should not allow those who have no knowledge of the pump to operate it.- Silicone grease is not applicable to this pump. It may cause extremely short lifetime of the pump or pump damage.
	<ul style="list-style-type: none">- After the end of daily work, at night, and on holidays, be sure to shut off the power air to this machine to release the gun so as to bleed the internal pressure. Any secondary accident such as pollution of installation, due to pump operation driven by worn-away packing or hose without shutting off the supply air, shall be attributable to the user's responsibility.- When replacing any part at maintenance, be sure to stop the air supply to the machine to avoid having fingers nipped because of a malfunction.- Use of the pump for other than its intended purpose could lead to personal injuries or damages on properties. Use the pump based on the product specifications.



AN UNCOMMON TECHNICAL RESOURCE
(413) 788-LUBE (5823)
www.LubeTechnologies.com

Table of Contents

- Preface	
- For Safe Operation	
- Warnings and Cautions	
- Precautions on Use	
1. Names and Materials of Parts	
1.1 Names and Materials of Parts	1
1.2 Contents of Package	1
2. Preparations before Operation	2
3. How to Operate the Machine	3
4. Maintenance and Inspection	
4.1 Troubleshooting and Corrective Measures	4
4.2 Maintenance and Inspection	4
5. Disassembly and Assembly	5
6. Parts Disassembly Drawing and Parts List	
6.1 880899 EPL-100	7
6.2 851985 Grease gun	7
6.3 852902 Pump assembly	8
7. Specification	
7.1 Specification	9
7.2 Dimensions	9
8. Limited Warranty	10



AN UNCOMMON TECHNICAL RESOURCE
(413) 788-LUBE (5823)
www.LubeTechnologies.com

1. Names and Materials of Parts

1.1 Names and Materials of Parts

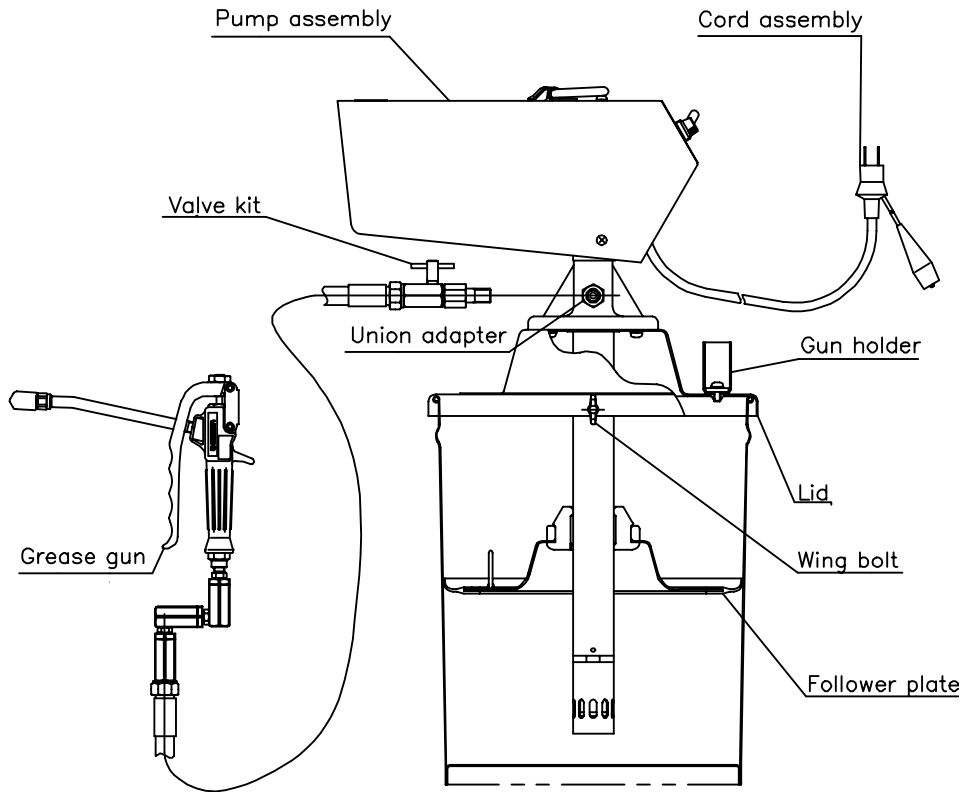

1.2 Contents of Package

This machine is packaged in a corrugated fiberboard case. Open the top lid of the corrugated fiberboard case and check the machine for damage.

2. Preparations before Operation

[Assembling the unit] (Fig. 1)

- 1) Insert the pump assembly in the center hole from the front side of the lid.
- 2) Fix the pump assembly and the lid with 3 pan-head screws from the rear side of the lid.
- 3) Connect the high-pressure hose for grease (separately available) to the valve kit at the pump discharge port and connect a high-pressure grease gun to the other end of the hose.

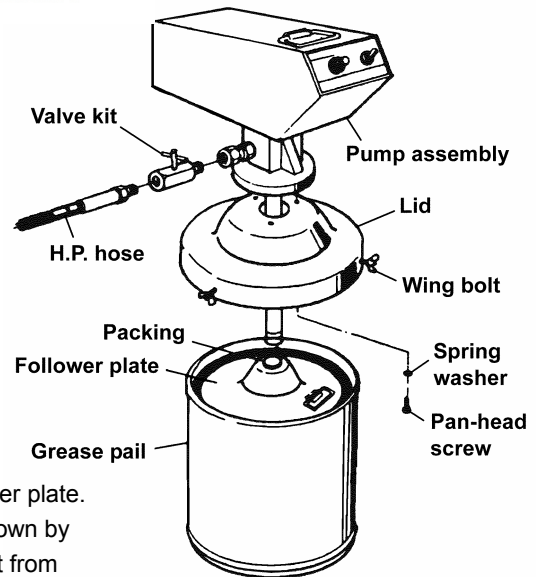

Fig. 1

[Setting the pump] (Fig. 1)

- 4) Remove the lid of a new grease can and set the attached follower plate. Place the follower plate on the grease horizontally and push it down by rubbing it to left and right with a hand until the grease comes out from the packing in the middle of the plate.

<Note>

When using the follower plate for the first time after purchasing the product, pack grease beforehand in the rear-side concave portion of the plate. This facilitates the work. (Fig. 2)

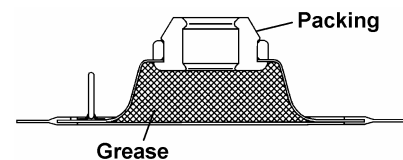

Fig. 2

- 5) Insert the pump in the packing in the middle of the follower plate and set the lid on the pail can. Fix it securely by screwing 3 wing bolts equally.

<Note>

Take extreme care not to allow sand and dust to adhere on the suction tube and follower plate of the pump assembly. Do not blemish the packing of the follower plate by the end of the lower pump.

[Connecting to power supply]

- 6) Place the unit on flat and stable place.
- 7) Connect the attached cord assembly (5 m) to the power supply.

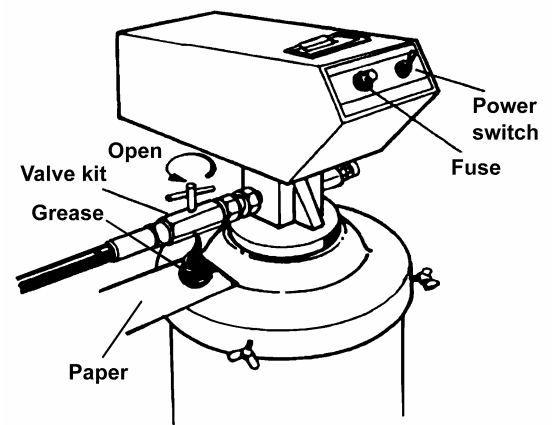
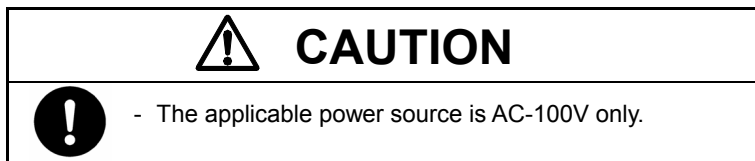

Fig. 3

[Bleeding air for grease] (Fig. 3)



- 8) The pump starts running by turning the switch ON. The first applied grease includes the internal air of the pump. This is not a good condition. Obtain a perfect condition by the next operation. First open the valve kit and operate the pump until grease is discharged from a small hole under the check valve. After grease is discharged in a perfect condition, close the valve kit. At this time, spread paper so that grease may not come into touch with the hand, and dispose of the discharged grease.

<Note>

The grease in which air is mixed is cloudy in white.

- 9) Discharge the air-mixed grease completely from the high-pressure grease gun and the hose by pulling the gun lever.

3. How to Operate the Machine

 CAUTION
<div style="display: flex; margin-bottom: 10px;"> <div style="text-align: center; margin-right: 10px;">  </div> <div> <p>- Do not operate the gun lever with the discharge port facing to another person during machine operation. A direct hit against the human body may result in an accident such as skin damage.</p> </div> </div> <div style="display: flex; margin-bottom: 10px;"> <div style="text-align: center; margin-right: 10px;">  </div> <div> <p>- Regarding a secondary accident such as hose damage that may be caused without shutting off of the air supplied to the hose or installation contamination due to a leak from the valve or gun after completion of the work or at night, the responsibility rests with the user side.</p> <p>- When the pump causes a malfunction or operation stop, do not disassemble the pump thoughtlessly and disassemble only necessary portions referring to <Troubleshooting and Corrective Measures> on page 4 and judging the situation properly.</p> </div> </div>

<Note>

The electric grease pump runs continuously even if the grease gun closed. When internal pressure goes up to 28 MPa, the grease is relieved by relief valve automatically. Thus this unit is overload free. The grease returns to pail through the outer tube.

- 1) Wipe the grease nipple to be used for greasing completely. After that, push the hydro chuck of the high-pressure grease gun against the nipple to perform chucking as vertically as possible. (Fig. 4)
- 2) Pull the lever of the high-pressure grease gun to supply grease. The pump is automatically operated to supply grease. When grease is normally injected, old grease will be squeezed out from the groove or clearance bear the nipple.
- 3) After completion of grease supply, release the gun lever. The grease supply will be stopped and the pump will also be stopped automatically.
- 4) Remove the hydro chuck of the grease gun. Since pressure is applied to the hydro chuck, the head of the nipple may be broken if it is suddenly pulled. Incline the hydro chuck to bleed the internal pressure and loosen the claw bite, and the chuck can be easily removed. (Fig. 5)
- 5) After completion of greasing work or when the pump is not used for a long time, be sure to shut off the supply air and bleed the internal air of the pump, grease gun, and hose by operating the gun lever.
- 6) If the pump is suddenly started, it may be due to non-existence of grease in the grease can or a cavity produced. Stop the greasing work and make a check. If the grease is used up, replace the grease can.

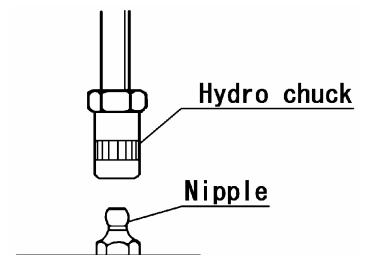

Fig. 4

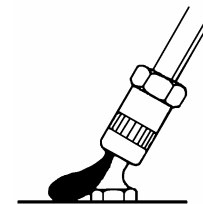



Fig. 5

[Replacing the grease can]

 CAUTION
<div style="display: flex; margin-bottom: 10px;"> <div style="text-align: center; margin-right: 10px;">  </div> <div> <p>- When replacing the grease can, be sure to shut off the supply air for safety and pull the gun lever to bleed the internal pressure of the pump and hose beforehand.</p> </div> </div>

- 7) Unscrew the 3 wing bolts of the lid, and remove the pump unit from used the grease can and take out the follower plate.
- 8) Remove the lid of a new grease can and place the follower plate on the grease horizontally and push the follower plate by rubbing it until grease comes out from the central hole.
- 9) Insert the pump in the packing in the middle of the follower plate and set the lid on the pail can. Screw the 3 wing bolts equally so fix the lid securely.



AN UNCOMMON TECHNICAL RESOURCE
 (413) 788-LUBE (5823)
www.LubeTechnologies.com

4. Maintenance and Inspection

4.1 Troubleshooting and Corrective Measures

Symptom	Contents of inspection	Corrective measure
◆ The pump fails to start.	<ul style="list-style-type: none"> - Check if the power cable is cut. - Check if the fuse is blown. - Uninstall the lower pump and operate only by the motor. <p style="text-align: center;">↓</p> <p>(Separate the lower pump and operate the pump with only the motor.)</p> <ul style="list-style-type: none"> → If the pump is operated, the lower pump is defective. → If the pump is not operated, the motor is defective. 	<ul style="list-style-type: none"> - Change to the new cable. - Change to new fuse (7A). - Repair service for the lower pump. - Repair service.
◆ The pump is operated but does not feed the material by pressure.	<ul style="list-style-type: none"> - Check if the delivery hose and grease gun is clogged up. - Check if the grease is ran out. - Check if the grease does not touch to the pump suction because of cavity or diagonal installation of the follower plate. - Uninstall the lower pump and operate only by the motor. 	<ul style="list-style-type: none"> - Remove the cause of clogging. - Replace to the new pail. - Install the follower plate horizontally and push down till the grease comes out from the packing. Then operate the pump again. - Check the lower pump.
◆ The pump is operated but the pressure and flow rate are insufficient.	<ul style="list-style-type: none"> - Check if leakage is found on the connection of valve kit, hose and gun. - Check if the relief valve is loosens. - Check if the valve seat at lower pump is worn out. 	<ul style="list-style-type: none"> - Tighten the connections - Adjust the relief valve at proper position. - Change to new valve seat.
◆ Grease leaks from the motor.	<ul style="list-style-type: none"> - Check if the seal packing between motor and material pump is worn out. 	<ul style="list-style-type: none"> - Change to new seal packing.
◆ The pump makes noise.	<ul style="list-style-type: none"> - Check if foot valve is stuck by foreign substance. 	<ul style="list-style-type: none"> - Remove the foreign substance.

4.2 Maintenance and Inspection

The hose is a consumable part. Check it periodically. If any blemish or leakage is found, replace the hose little earlier. The packing and slide portion parts of the pump are worn away. Check and replace them once a year.

5. Disassembly and Assembly



CAUTION



- Gasoline is a high volatile fuel. Do not use it to clean the pump in any case, otherwise ignition or explosion may be caused.
- When washing parts, do not use such a liquid as corrodes aluminum, copper alloy, iron, etc.



- Before disassembling and inspecting the machine, be sure to shut off the power supply and open the outlet valve to release the internal pressure of the pump.

[Disassembling the lower pump]

When the trouble such as unstable operation or pump stop, do not disassemble the pump immediately. First refer <Troubleshooting and Corrective Measures> on page 4 and confirm the situation of the pump unit. Do not disassemble the part that is not concerned with the trouble.

- 1) Shut off the power supply. Bleed the internal pressure of the pump and hose and remove the air chuck and high-pressure hose from the pump.
- 2) Unscrew 3 wing bolts that fix the lid and the pail, and dismount the unit from pail.
- 3) Unscrew 3 pan-head screws that fix the pump and the lid, and disassemble the lid from the pump.
- 4) Fix the pump assembly on vise. (Fig.6)
- 5) Set a spanner on the valve adapter and unscrew it. The out tube can be pulled out from the pump. Then continue to pull out it until touching to the plate, the union that connects to the motor. Pull out the pin and unscrew the union, and the lower pump can be separated from the motor. (Fig. 6)
- 6) Pull out the out tube. If only the valve adapter pulled out, unscrew the nut and remove the plate. Then pull out the out tube and screw the suction tube with pipe wrench (set on notched part of the suction tube). Pull out the pin and unscrew the union, and the lower pump can be separated from the motor. (Fig. 6, 7)
- 7) Fix the cylinder part of the lower pump on vise. Set a spanner on the valve adapter and unscrew it. The valve seat, the foot valve and the valve ring can be removed. (Fig. 8)
- 8) Set a pipe wrench on notched part of the suction tube and unscrew it. The piston valve assembly can be removed. (Fig. 9)
- 9) Flatten the bending part of the washer that fixes the union and the piston. Separate the union and the piston with a spanner, and then remove the ball and the spring. (Fig. 9)
- 10) Wash each part and if damage and wear found, change to the new parts. Especially if the metal seal parts are damaged or wear out, grease will leak and discharge pressure cannot be increased, and consequently discharge volume will be decreased. In this case the piston and the cylinder must be changed to the new parts simultaneously. (Fig.10)

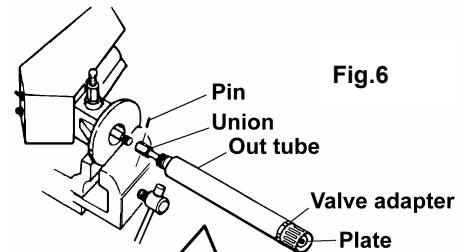

Fig.6

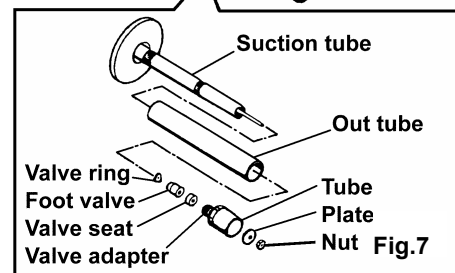

Fig.7

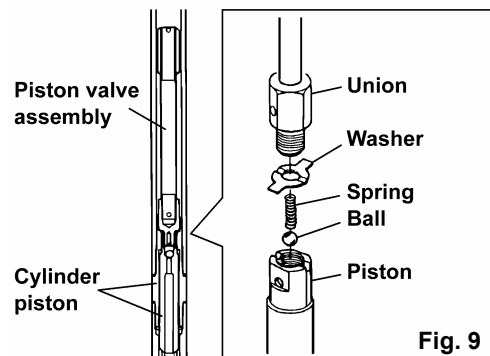

Fig. 9

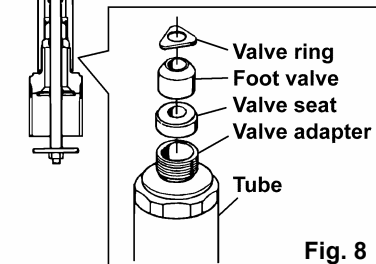

Fig. 8

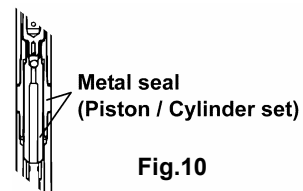

Fig.10

[Assembling the lower pump]

- Assembling the intake valve

- 11) Insert the ball into the piston. Insert the spring into the union.
 Put the washer between the piston and the union, and then connect each other. This time keep the both edge of the washer right-angled position against the side of the hexagon part of the union. Then screw the union with a spanner and fix to the piston firmly. Bend the both edge of the washer to the direction to the union. This plays a role of stopper. (Fig.11)

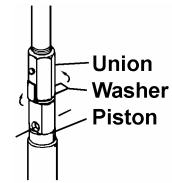

Fig.11

- Assembling the foot valve

- 12) Insert the intake valve assembly to the suction tube.
 (Fig.12)
- 13) Insert the valve ring, the foot valve and the valve seat in order of it. Be sure the direction of each part is correct.
 (Fig.12)
- 14) Screw the valve adapter and the tube.
 Install the plate with the nut. (Fig.12)
- 15) Insert the suction tube from opposite side of valve adapter.
 Pull out the union from the suction tube and screw it to the connecting rod of the motor side. Adjust the position of pin-hole of both the suction and the union, and insert the pin.
 (Fig. 6)
- 16) Screw the suction tube into the crankcase of the upper motor with hands. Then fix it firmly by a spanner.

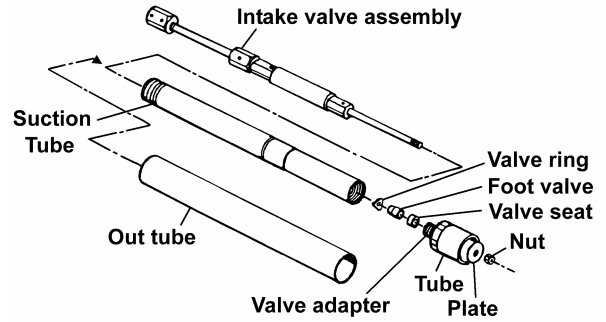

Fig.12

[Disassembling the upper motor] (Fig.13)

- 17) Remove the packing retainer with tweezers.
- 18) Remove the packing and the back up ring with tweezers.
- 19) When replace these to new parts, put little grease on the packing and install with correct direction.

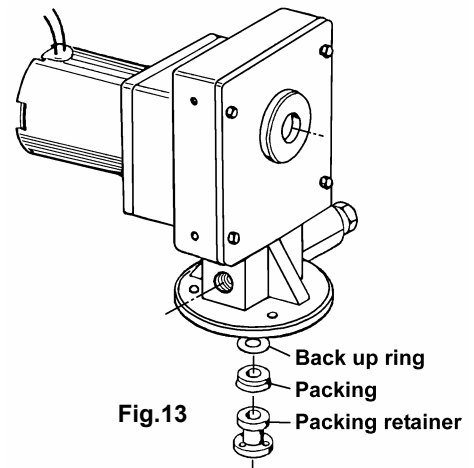



Fig.13

[Adjusting the relief valve] (Fig.14)

The relief valve is adjusted its pressure to 28 MPa and fixed in assembling at factory. Basically adjusting is not necessity. If the relief valve is loosened by some reason, adjust with the procedure shown below.

 CAUTION
If the following points are not defended, the accident resulting In injury or death and damage might be caused.

1. Remove the delivery hose and the valve kit, and then install high-pressure ball vane with pressure gauge (Max. 50 MPa) instead of the hose and the valve kit.
2. Operate the pump. After checking grease discharge, shut off the high-pressure ball valve. Adjust the relief valve to make the pressure gauge points 28 MPa. Tighten the nut and fix the relief valve firmly.

3. [Adjusting method without pressure gauge]

One revolution from the position where the bolt touched the guide increases relief pressure approx 26 MPa. Screw the bolt 30 degree more, then tighten the nut and fix the bolt.
 (Fig.15)

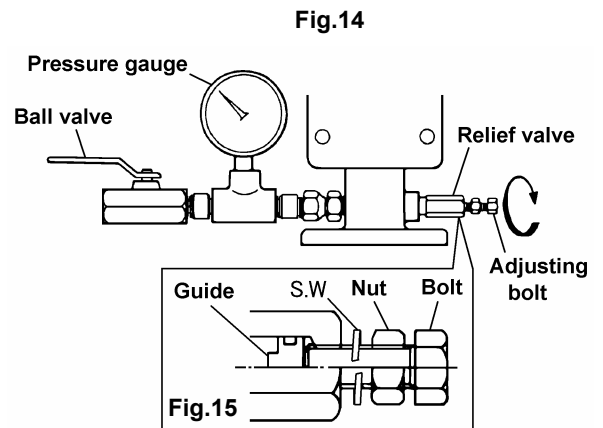
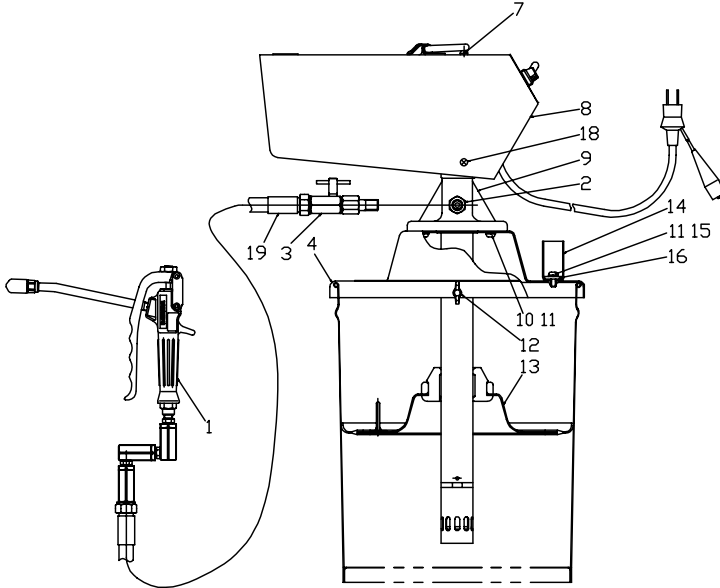

Fig.14

Fig.15

6. Parts Disassembly Drawing and Parts List

6.1 880899 EPL-100



REF.No.	Parts No.	Description	Q'ty
1	851985	Grease gun assembly	1
2	680080	Union adapter	1
3	803903	Valve kit	1
4	710915	Lid	1
7	683347	Screw with washer	2
8	803662	Cover assembly	1
9	852902	Grease pump assembly	1
10	602296	Pan-head screw	3
11	631418	Spring lock washer	4
12	610623	Wing bolt	3
13	803085	Follower plate assembly	1
14	707937	Gun holder	1
15	602298	Pan-head screw	1
16	707880	Plain washer	1
18	683860	Screw with washer	2
19	695034	Hose	1

6.2 851985 Grease gun

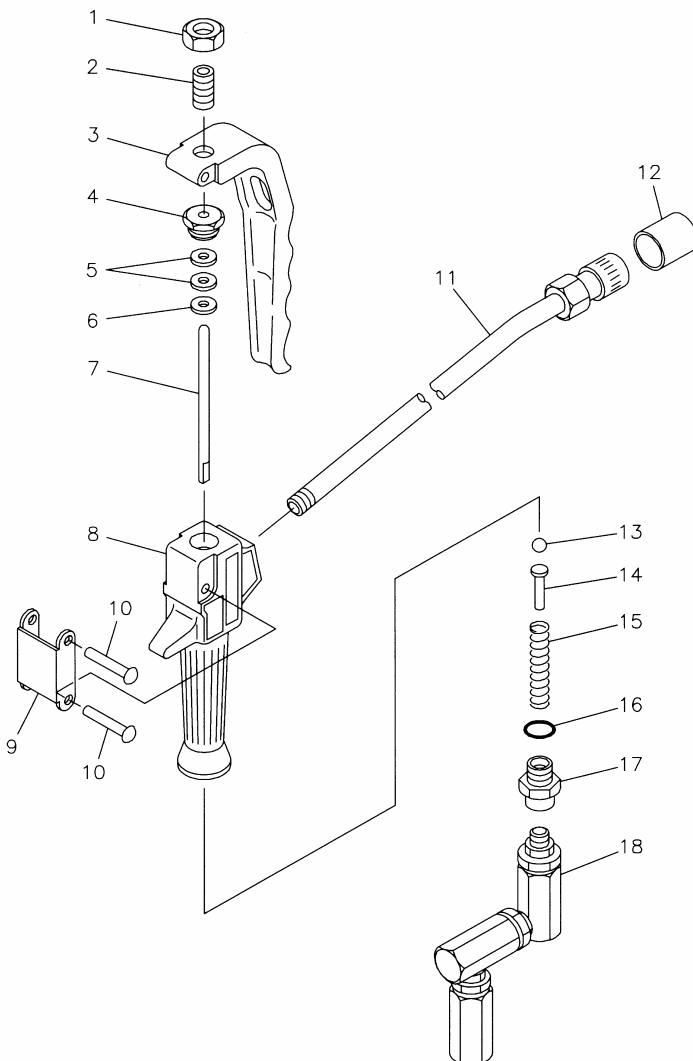

REF.No.	Parts No.	Description	Q'ty
1	627641	Nut	1
2	711750	Bolt	1
3	711354	Lever	1
4	711444	Retaining nut	1
5	772160	Packing	2
6	713638	Washer	1
7	711357	Rod	1
8	711352	Body	1
9	711351	Link	1
10	683201	Rivet	2
11	800531	Nozzle assembly	1
12	685728	Cap	1
13	630314	Ball	1
14	711445	Spring retainer	1
15	711446	Spring	1
16	640011	O ring	1
17	710971	Union	1
18	802910	Swivel joint assembly	1

REF No.3,8,9 and No.10 are undissolution.

6.3 852902 Pump assembly

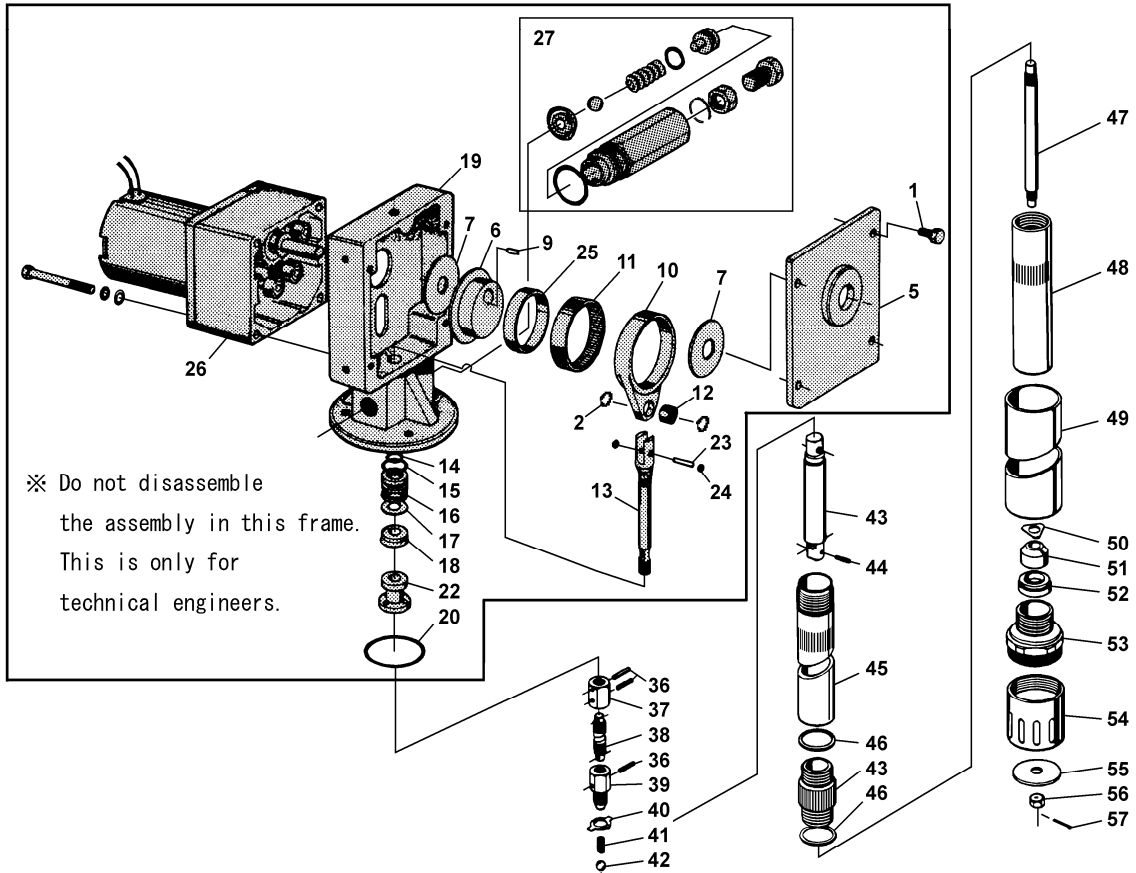

REF.No.	Parts No.	Description	Q'ty	REF.No.	Parts No.	Description	Q'ty
1	682262	Bolt	4	36	702971	Pin	3
2	713239	Washer	2	37	706091	Union	1
5	832933	Cover assembly	1	38	709643	Rod	1
6	713231	Cam	1	39	702975	Union	1
7	713230	Stopper	2	40	702974	Washer	1
9	716029	Key	1	41	702976	Spring	1
10	713240	Rink	1	42	630313	Ball	1
11	682995	Needle bearing	1	43	801051	Cylinder assembly	1
12	684347	Ball bearing	2	44	632754	Spring pin	1
13	832192	Connecting rod	1	45	709642	Suction tube	1
14	640009	O ring	1	46	702977	Washer	2
15	640014	O ring	1	47	706399	Plunger rod	1
16	710813	Bush	1	48	706072	Foot tube	1
17	771405	Back up ring	1	49	710815	Out tube	1
18	771418	U-Packing	1	50	702980	Valve ring	1
19	715988	Crank case	1	51	771404	Foot valve	1
20	640037	O ring	1	52	702982	Valve seat	1
22	710896	Packing retainer	1	53	830407	Valve adapter	1
23	710808	Pin	1	54	712043	Tube	1
24	630779	Stop ring	2	55	702984	Plate	1
25	682994	Inner case	1	56	627010	Nut	1
26	684336	Motor	1	57	632019	Split pin	1
27	802587	Relief valve assembly	1				

7. Specification

7.1 Specification

Type	EPL-100
Model No.	880899
Rating	Continuous rating
Discharge volume	2~3.17g/sec
Discharge pressure	0~28MPa
Max discharge pressure	28MPa (30 minute rating)
Rotational speed	90 ~ 145 RPM
Power supply	AC-100 V (50/60 Hz)
Vibration resistance	3.5 G
Applicable grease	NLGI No.0 ~ 2
Applicable temperature	-10 °C ~ 40 °C
Weight	13 kg
Equipped accessories	851985 Grease gun 803085 Follower plate 802493 Cord assembly (5 m, with connector) 710915 Lid 695034 High-pressure delivery hose (G1/4x2.5M) 803903 Valve kit
Option	851245 Hose reel (SHR-3C15) 851243 Hose reel (SHR-3C10) 851003 Carry (S-20) 683239 Dustproof cover

7.2 Dimensions

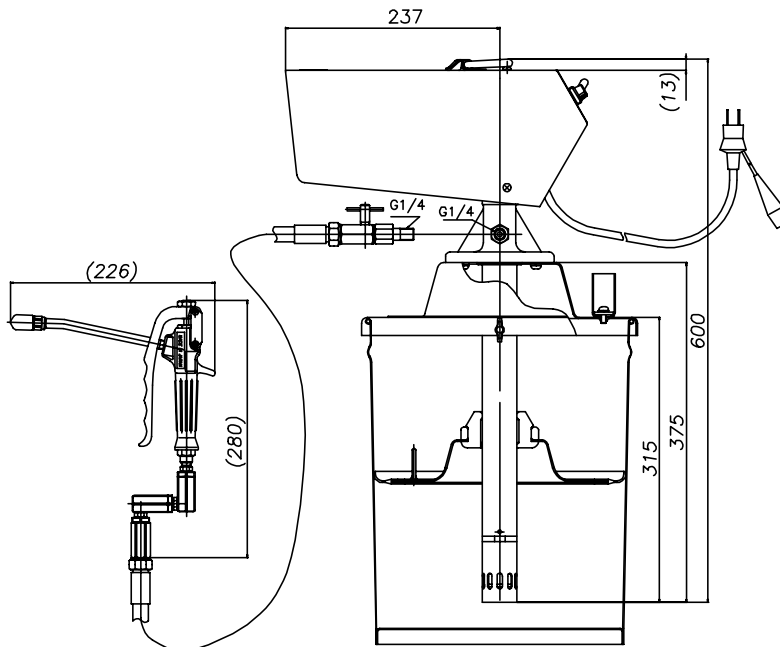



AN UNCOMMON TECHNICAL RESOURCE
(413) 788-LUBE (5823)
www.LubeTechnologies.com

8. Limited Warranty

- This product is shipped to customers only after meeting strict inspection standards. If an abnormality occurs during normal operation in accordance with the operating instructions and other operating cautions within the warranty period (12 months after date of purchase) that can be attributed to a manufacturing defect, the defective parts of this product will be serviced or the product will be replaced free of charge. However, this warranty will not cover compensation for incidental damage or any malfunction listed below.

1. Warranty period

This warranty will be valid for a period of 12 months after the date of purchase.

2. Warranty

If, during the warranty period, any of the material of the genuine parts of this product or the workmanship of this product is found defective, and is so verified by our company, the servicing cost will be fully born by our company.

3. Exclusion

Even during the warranty period, this warranty does not cover the following:

- 1) Malfunction arising from use of parts other than manufacturer-specified genuine parts
- 2) Malfunction arising from misuse or operating errors, or lack of storage or maintenance care
- 3) Malfunction arising from use with a fluid that may cause corrosion, inflation or dissolution of the component parts of the product
- 4) Irregularity arising from repair made by other than by our firm, our regional office, dealer or authorized service personnel
- 5) Malfunction arising from modification of the product by other than authorized service personnel
- 6) Wear and tear of parts that must be regularly replaced in the course of normal operation, such as packings, O-rings, balls, and valve seats
- 7) Malfunction and/or damage due to transportation, moving or droppage of the product after purchase
- 8) Malfunction and/or damage due to fire, earthquake, flood or other force majeure
- 9) Malfunction arising from use of compressed air that contains impurities or excessive moisture, or use of gases or fluids other than the specified compressed air
- 10) Malfunction arising from use with a fluid that causes excessive abrasion or use of lubricating oil other than that specified for this product

Furthermore, this warranty does not cover the rubber parts, or other parts that are subject to wear in normal operation, used in this product and its accessories.

4. Parts

Parts for this product will be kept available for 5 years after discontinuation of production. Once 5 years have elapsed after close of production, availability of parts for this product cannot be guaranteed.



AN UNCOMMON TECHNICAL RESOURCE

(413) 788-LUBE (5823)

www.LubeTechnologies.com

Manufactured by

YAMADA CORPORATION