

Product Information



Xtract™ Contamination Removal

Xtract™ High Temperature Oil Sight Glass

Inspect oil and drain water out of reservoirs in high-temperature operating conditions.

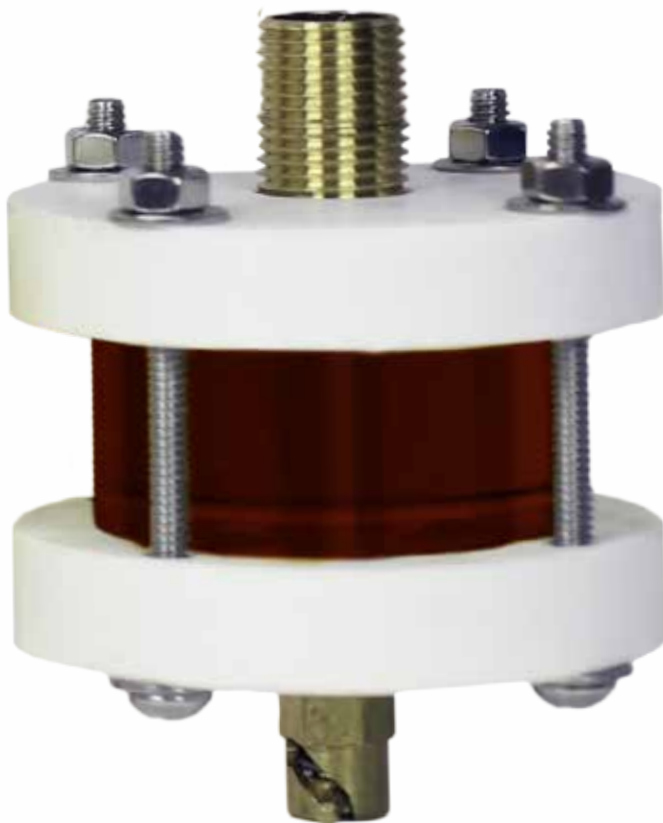

Applications

- Pumps
- Gearboxes
- Storage tanks
- Fluid-lubricated machinery



Xtract™ High Temperature Oil Sight Glass

Key Benefits

- Designed for high-temperature applications up to 450°F
- 360° view of oil clarity
- Easily collect and drain water
- Stain-resistant Pyrex® glass
- Easy to install

Description

The High Temperature Oil Sight Glass (OSG) was developed for applications where oil operating temperatures or radiant heat from adjacent equipment exceeds or is continually at or near the standard Oil Sight Glass's operating range. Made of Pyrex® and Teflon®, this design will allow users to have an immediate visual inspection of the oil and the ability to drain any accumulated water, even when exposed to temperatures up to 450°F.

By the Numbers

- 1- Brass Nipple (optional stainless steel)
- 2- Stainless Steel Bolts
- 3- Teflon Cap
- 4- Overall Length
- 5- Pyrex® Glass with Collected Water
- 6- 1/4" NPT Brass Drain Valve (optional stainless steel or magnet drain)
- 7- Diameter of Teflon Cap

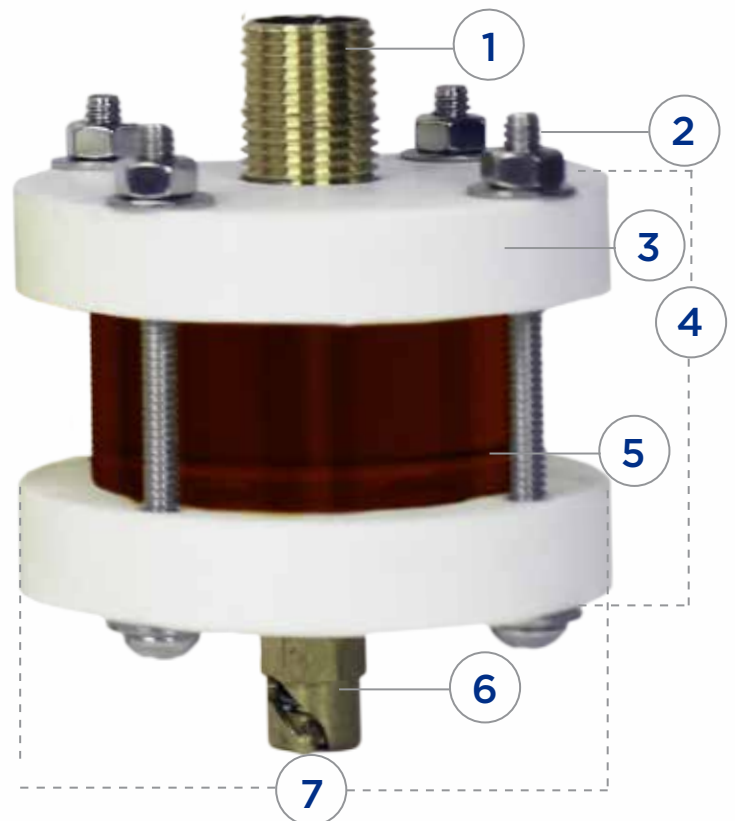



Material

- Heavy-walled Pyrex® glass
- Teflon® end plates
- Viton® O-rings
- Stainless steel nuts and bolts
- Brass fittings standard

Recommended Operating Range

- -40°F to 450°F
- -40°C to 232°C

Pressure Rating

- Up to 65 psi
- 4.48 bar

Chemical Compatibility

- All gear, mineral, and synthetic oils

Available Options

- 1/4", 3/8", and 1/2"NPT ports
- 1oz and 3oz sizes
- Stainless steel fittings
- Magnetic drain valve for collecting ferrous material

Sizing

Description	Part Number	Overall Length		Outside Diameter	
		(in)	(cm)	(in)	(cm)
1oz X 1/4" NPT	LEXOHT250-1	2.5	6.35	2.75	6.99
1oz X 3/8" NPT	LEXOHT375-1	2.5	6.35	2.75	6.99
1oz X 1/2" NPT	LEXOHT500-1	2.5	6.35	2.75	6.99
3oz X 1/4" NPT	LEXOHT250-3	2.5	6.35	3.50	8.89
3oz X 3/8" NPT	LEXOHT375-3	2.5	6.35	3.50	8.89
3oz X 1/2" NPT	LEXOHT500-3	2.5	6.35	3.50	8.89



Does the Oil Sight Glass replace the need for oil filtration?

While the OSGs will isolate and remove free-flowing water, it is still recommended that you use other filtration systems to remove all water contamination from your oil. The OSG will be an early indicator of contamination problems and can help find the source of such problems, but the OSG alone will not prevent moisture from entering your reservoir or remove any water that has become emulsified in the oil. Contact us at info@LE-inc.com for more information on filtration systems.

Does the Oil Sight Glass work with all oils?

Yes, the OSG will collect sediment and free-flowing water from any oils. They are best used with high-quality synthetic oils, as synthetics tend to do a more efficient job separating water.

Do I still need a desiccant breather if using the Oil Sight Glass?

Yes. Desiccant breathers prevent moisture and contaminants from entering the fill port of equipment and pull moisture from the headspace. However, a desiccant breather cannot remove large amounts of water already mixed into the oil. That is why combining the use of desiccant breathers with oil filtration and an OSG to isolate and remove free-flowing water from the oil is best practice. Additionally, the OSG will act as an early indicator of a contamination problem.

Can I pull an oil sample from the Oil Sight Glass?

Water and other contaminants tend to sink to the bottom of a reservoir. Because of this, samples taken from the OSG will typically be “dirtier” than the rest of the oil in the reservoir. Best practice dictates that a sample should be drawn from the center of an oil reservoir. Sampling tubes can be used in conjunction with the OSG to draw a representative oil sample to be analyzed.

Can the Oil Sight Glass replace my oil sampling program?

Oil sampling and analysis is still recommended, as it is best practice. The OSGs are part of a comprehensive preventative maintenance program, and they will show users early indications of various forms of contamination.

I’m concerned about the Oil Sight Glass breaking. What can I do to prevent this?

First, try to install the OSG in a location that is protected from mobile equipment or other high-impact hazards. It is also recommended that users install a ball-valve between the drain port and the OSG. The ball-valve allows instantaneous shut off of oil flow if necessary.

How can I clean/replace the Oil Sight Glass products without having to drain the oil from my equipment? Installing a ball-valve between your drain port and the OSG will allow users to shut off the flow of oil in order to clean or replace the product. Cleaning the products typically requires just soap and water.