

Product Information

Xclude™ Contamination Exclusion



Xclude™ Rebuildable Steel Breather

For high-flow applications



Applications

- Bulk storage
- Chemical/harsh environments
- Hydraulic reservoir
- Diesel tank storage

Highlights

- Carbon or stainless steel housing
- Easy-to-replace desiccant bags remove moisture from incoming air
- Replaceable filter removes particles to 1-micron absolute ($\beta_{1\geq 1000}$)
- Eliminates rust-forming condensation
- Prevents sludge deposits and water-contaminated fluid
- Reduces wear and tear on equipment, prolongs life



AN UNCOMMON TECHNICAL RESOURCE

(413) 788-LUBE (5823)

www.LubeTechnologies.com

AUTHORIZED DISTRIBUTOR



Asset Reliability Solutions™

Overview



By the Numbers

1–Pleated Filter Element

Filter element captures airborne contamination to 1-micron absolute ($\beta_{0.3} \geq 1000$).

2–Desiccant

Silica gel strips moisture from incoming air. Desiccant can be customized to mitigate a variety of chemicals or fumes.

3–Outside Sight Glass Indicator

Silica gel changes color from blue to light pink when the unit requires component replacement (or rebuilding).

4–Air Vents

Removable stickers keep breather inactive until installation.

5–Integrated Standpipe

Resilient construction provides durability and allows oil mist to coalesce and drain back into the reservoir.

6–Foam Pad

Foam filter captures any large particles and disperses incoming air evenly over filtration and drying areas.

7–Easy-to-Replace Desiccant Bag

Polypropylene bag has handles for easy removal.

8–Rugged Housing

Powder-coated carbon steel or stainless steel housing provides excellent protection against the elements.

How It Works

This breather unit replaces the standard dust cap or OEM breather cap on equipment. As air is drawn into equipment through the breather, the pleated filter element removes solid particulates while the desiccant extracts moisture.

While in service or during shutdown, the desiccant beads attract moisture from inside the equipment reservoir, actively drying the equipment.

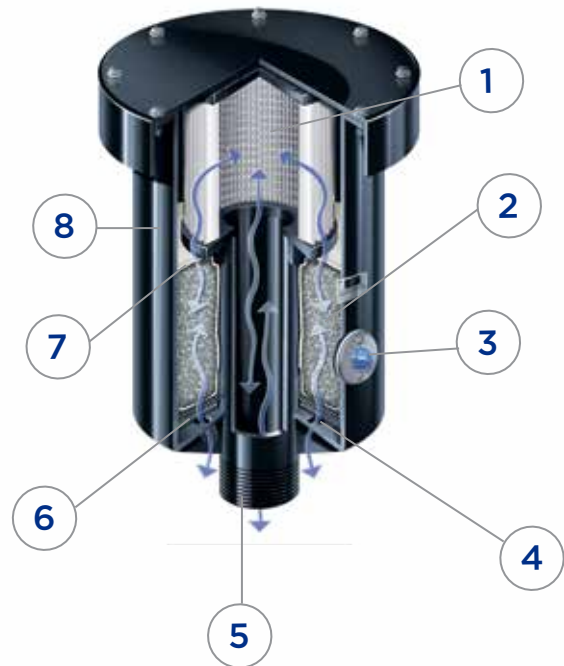

Customization of Materials

Steel Housings

- Carbon steel*
- 304 Stainless steel
- 316 Stainless steel

Media

- Silica gel*
- Activated carbon
- Molecular sieve
- Activated alumina

Gasket/Seal Material

- Buna-N*
- Viton®
- EPDM
- SBR rubber

Filter Material

- Microglass*
- Polyurethane filter
- Plastisol filter

*Standard Component

40+ LUBRICATION
1976-2016 YEARS Technologies Inc.
AN UNCOMMON TECHNICAL RESOURCE
(413) 788-LUBE (5823)
www.LubeTechnologies.com
AUTHORIZED DISTRIBUTOR



Rebuild Kits

Rebuild Kit Components

Replacement Filter Element

Pleated filter element captures airborne contamination to 1-micron absolute.



Desiccant Bag Filter

Polypropylene bag has handles for easy removal and replacement.¹



Sight Glass Indicator

Silica gel changes color from blue to pink when the unit requires rebuilding.



(413) 788-LUBE (5823)

www.LubeTechnologies.com

AUTHORIZED DISTRIBUTOR



Rebuild Parts & Accessories

Model #	Description
LEXRS-RK	Rebuildable Steel Breather Kits
LEXRS-F1	Rebuildable Steel Breather Microglass Filter Elements
LEXRS-D1	Rebuildable Steel Breather Desiccant Bag Sets
LEXRS-SG1	Rebuildable Steel Breather Sight Glass Cartridges
LEXRS-P1	Rebuildable Steel Breather Foam Pad Inserts
LEXRS-G1	Rebuildable Steel Breather Gasket Seals

LE recommends use of a pressure/relief valve on any tank or storage system.

¹ Desiccant bags for units above an LEXRS-25 are packaged in 25lb increments for easy handling

Product Specs

	LEXRS2-3	LEXRS2-5	LEXRS2-9	LEXRS3-15	LEXRS3-25	LEXRS3-50	LEXRS3-75	LEXRS4-100	LEXRS4-150	LEXRS4-200
Height (in/cm)	11.5/29.2	13.75/34.9	18.25/45.4	19.25/48.9	22.5/57.1	31.25/79.4	39.75/101	31/78.7	36.75/93.3	42.75/106.6
Width (in/cm)	10.1/25.7	10.1/25.7	10.1/25.7	15.5/39.4	15.5/39.4	15.5/39.4	15.5/39.4	23.5/59.7	23.5/59.7	23.5/59.7
Approx. Dry Weight (lb/kg)	16/7.26	20/9.07	27/12.25	49/22.23	64/29.03	100/45.36	144/65.32	190/86.18	253/114.76	315/142.88
Amnt. of Desiccant (lb/kg)	3/1.36	5/2.27	9/4.08	15/6.80	25/11.34	50/22.68	75/34.02	100/45.36	150/68.04	200/90.72
Max. Adsorption Capacity (gal/L)	0.14/0.54	0.24/0.9	0.43/1.62	0.71/2.7	1.19/4.5	2.38/9	3.57/13.5	4.75/18	7.13/27	9.51/36
Max. Airflow Rate	85 @ 0.5psid	85 @ 0.5psid	80 @ 0.5psid	205 @ 0.5psid	140 @ 0.5psid	115 @ 0.5psid	80 @ 0.5psid	270 @ 0.5psid	250 @ 0.5psid	240 @ 0.5psid
Operating Temp.	-20-220°F/-29-104°F									
Connection Size	2"	2"	2"	3"	3"	3"	3"	4"	4"	4"
Body Material	Carbon steel, Polyurethane, Polypropylene, Microglass, Polycarbonate, Nomex, Buna-N (silica gel as hydrophilic agent)									

*Desiccant weight may vary up to 0.5lb for easy handling.



AN UNCOMMON TECHNICAL RESOURCE

(413) 788-LUBE (5823)

www.LubeTechnologies.com

AUTHORIZED DISTRIBUTOR

